

PKK1



Nominal size				Max working pressure	Rated flow	Max flow rate	Min burst pressure			Fluid spillage
DNP	BG	ISO	mm				Male	Female	Coupled	
13	3	12.5	10,5	25 Mpa	45 l/min	90 l/min	100 MPa	140 MPa	120 MPa	2,7 cc

Caratteristiche tecniche

- Norma: ISO 7241-1 A
- Occlusione: valvola decompressione
- Aggancio: sfere radiali
- Materiale: acciaio
- Finitura: Zn-Fe (Cr III)
- Filettature: BSP – NPT – RC – SAE
- Guarnizioni standard: NBR
- Temperatura d'esercizio: -25 °C +100 °C
- Guarnizioni opzionali: FKM, EPDM o altro
- Pressioni di esercizio: 250 bar
- Connessione in pressione: consentita (lato maschio e lato femmina)
- Massima pressione residua: 250 bar

Technical data

- Standard: ISO 7241-1 A
- Occlusion: decompression valve
- Locking: radial balls
- Material: steel
- Finishing: Zn-Fe (Cr III)
- Threads: BSP – NPT – RC – SAE
- Standard seals: NBR
- Working temperature: -25 °C +100 °C
- Optional seals: FKM, EPDM or more
- Working pressure: 250 bar
- Connection under pressure: allowed (both male and female side)
- Max residual pressure: 250 bar

Technische Merkmale

- Norm: ISO 7241-1 A
- Verschluss: Dekompressionsventil
- Kupplung: Radialkugeln
- Werkstoff: Stahl
- Ausführung: Zn-Fe (Cr III)
- Gewinde: BSP – NPT – RC – SAE
- Standard-Dichtungen: NBR
- Betriebstemperatur: -25 °C +100 °C
- Dichtungen nach Wahl: FKM, EPDM, usw.
- Betriebsdruck: 250 bar
- Kuppeln unter Druck: erlaubt (Steckerseite und Muffeseite)
- Max. Restdruck: 250 bar

Caracteristiques techniques

- Norme: ISO 7241-1 A
- Obturation: clapet décompression
- Accrochage: billes radiales
- Matériel: acier
- Traitement: Zn-Fe (Cr III)
- Taraudage: BSP – NPT – RC – SAE
- Joints standard: NBR
- Température de service: -25 °C +100 °C
- Joints facultatifs: FKM, EPDM, ect.
- Pression de service: 250 bar
- Connexion sous pression: possible (côté male et femelle)
- Pression restante max: 250 bar

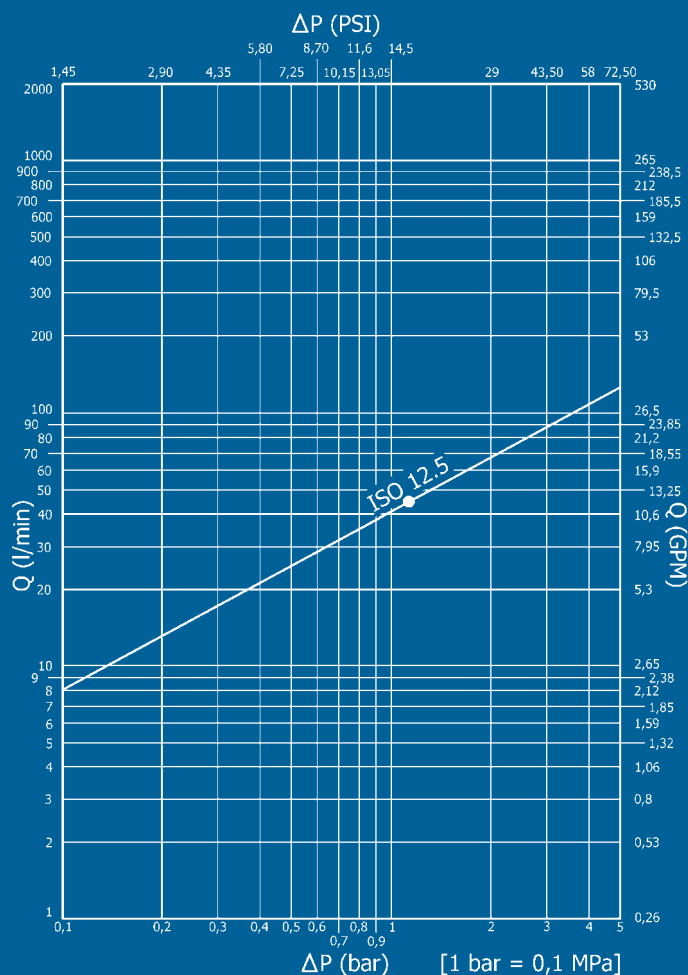

PKK1 DN13 - BG 3 - ISO 12.5

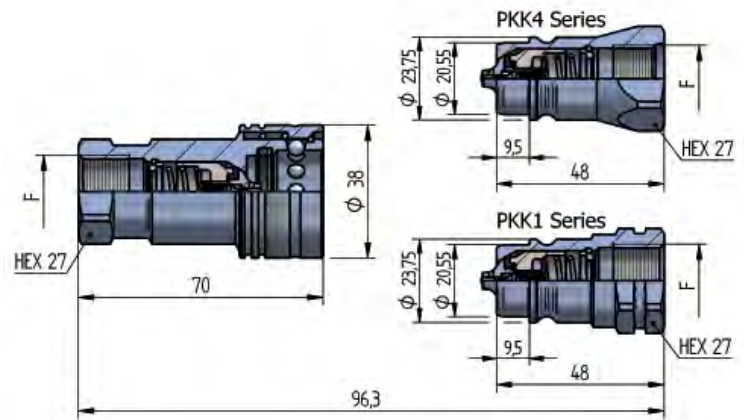

THREADS	F	STANDARD	FEMMINA - FEMALE - MUFFE - FEMELLE			MASCIO - MALE - STECKER - MALE		
			COD. F	Weight (g)	Packaging (pcs.)	COD. M	Weight (g)	Packaging (pcs.)
IG1	BSP 1/2"	DIN 3852-2-X	PKK1.1313.002	267	50	PKK1.1313.003	96	200
	BSP 1/2"	DIN 3852-2-X				PKK4.1313.003	93	200
	NPT 1/2"	ANSI B1.20.3	PKK1.1313.012	268	50	PKK1.1313.013	97	200
	RC 1/2"	UNI ISO 7/1	PKK1.1313.042	268	50	PKK1.1313.043	97	200
IG2	M22x1,5	SAE J 2244/1	PKK1.1322.102	259	50	PKK1.1322.103	89	200
	3/4"-16 UNF 2B	SAE J 1926-1	PKK1.1319.032	273	50	PKK4.1319.033	100	200

THREADS

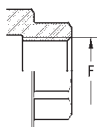

IG 1

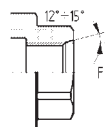

IG 2

PLASTIC



NOMINAL SIZE			FEMALE DUST PLUG			MALE DUST CAP			COLOUR	MATERIAL
DNP	BG	ISO	COD. F	Weight (g)	Packaging (pcs.)	COD. M	Weight (g)	Packaging (pcs.)		
13	3	12.5	SPAV.13002	20	50	SPAV.13003	21	50	RED	PVC
13	3	12.5	SPAV.13012	20	50	SPAV.13013	21	50	YELLOW	PVC
13	3	12.5	SPAV.13022	20	50	SPAV.13023	21	50	GREEN	PVC
13	3	12.5	SPAV.13032	20	50	SPAV.13033	21	50	BLUE	PVC
13	3	12.5	SPAV.13042	20	50	SPAV.13043	21	50	BLACK	PVC
13	3	12.5	SPAV.13052	20	50	SPAV.13053	21	50	WHITE	PVC

METAL



NOMINAL SIZE			FEMALE DUST PLUG			MALE DUST CAP			COLOUR	MATERIAL
DNP	BG	ISO	COD. F	Weight (g)	Packaging (pcs.)	COD. M	Weight (g)	Packaging (pcs.)		
13	3	12.5	SPAV.13202	51	50	SPAV.13203	70	50	-	Aluminium

GUARNIZIONI DI RICAMBIO / SPARE PARTS / ERSATZDICHTUNGEN / JOINTS

AL CODICE DELLA GUARNIZIONE IN NBR AGGIUNGERE 'E' PER EPDM o 'V' PER VITON

TO THE NBR GASKET CODE ADD 'E' FOR EPDM OR 'V' FOR VITON

ZU DER ARTIKELNR. DER NBR DICHTUNG GEBEN SIE 'E' FUER EPDM ODER 'V' FUER VITON AN

AU CODE DU JOINT EN NBR JOINDRE 'E' POUR EPDM OU 'V' POUR VITON

NOMINAL SIZE			FEMALE GASKET	
DNP	BG	ISO	NBR	PTFE
13	3	12.5	PAV.013.120	PAV.013.130